

Thermostatic Bath Shower Mixer

INSTALLATION & USER MANUAL

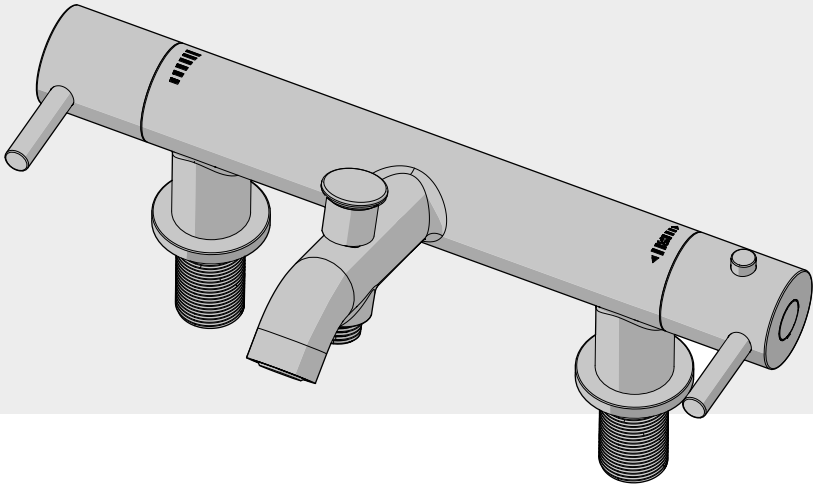

Please read all instructions before installation and leave this document with the end user for future reference as it contains important warranty information

Important Information

Dimensions

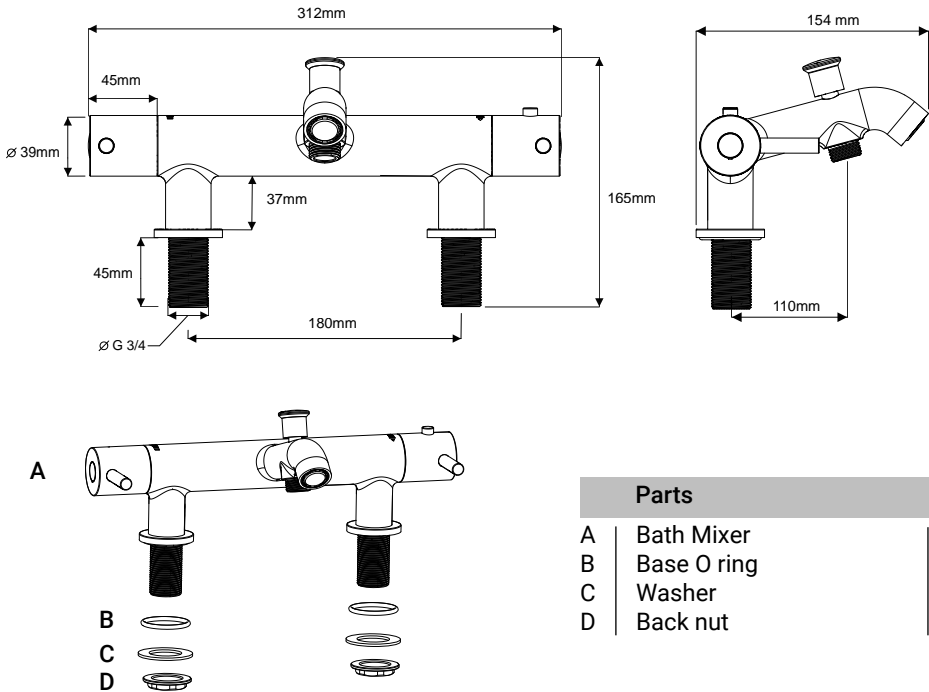

Parts	QTY
A Bath Mixer	1
B Base O ring	2
C Washer	2
D Back nut	2

Installation must be carried out in accordance with these instructions, and must be conducted by qualified and competent installer.

This product must be installed in compliance with Water Regulations. You may need to fit the optional Flow limiter to meet local requirements. Hot and cold water supply pressures should be balanced, isolating and non-return valves should be fitted. If you are unsure, please obtain the advice of a professional plumber before attempting any work.

Water Pressure

These taps are suitable for low and high pressure systems.

These taps should not be used with pressures exceeding 5 Bar. Min Pressure 0.2bar.

Where the supplies are unbalanced, i.e. Hot water from cylinder tank / cold from the mains, approved check valves must be fitted in the supply pipes. If the mains pressure is over 5bar, then a pressure reducing valve should be fitted. If the taps or mixers are installed to low pressure (tank fed), then the minimum height from the outlet of the nozzle to the underside of the cold tank should be 1.8 metres to ensure adequate performance.

Important: Access must be made available to the water supplies and fixings for future maintenance and servicing.

Warning! Before installation, it is essential that you thoroughly flush through the supply pipes to remove any remaining swarf, solder or other impurities. Failure to do so could cause damage to the internal workings of the tap. AKW will not accept responsibility for any problems that occur through incorrect installation. ISOLATE THE WATER SUPPLY.

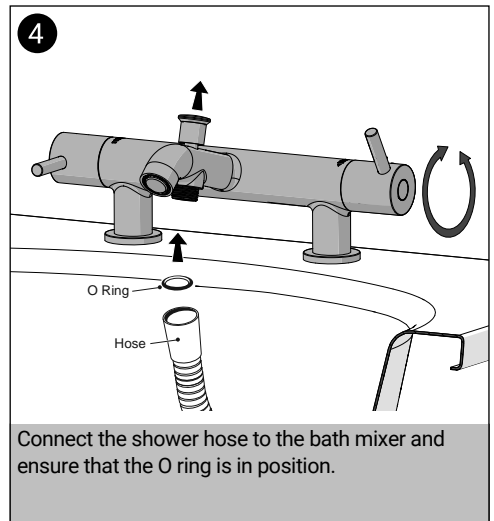
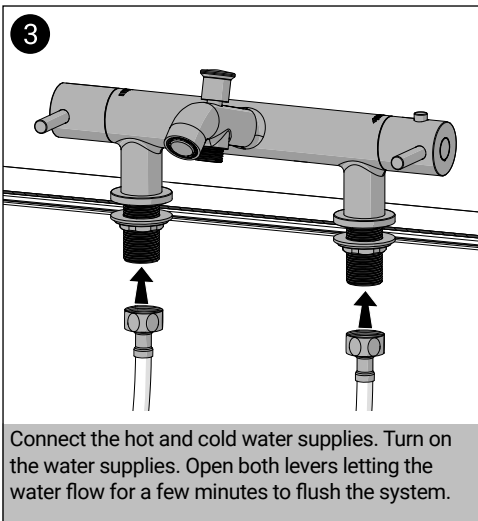
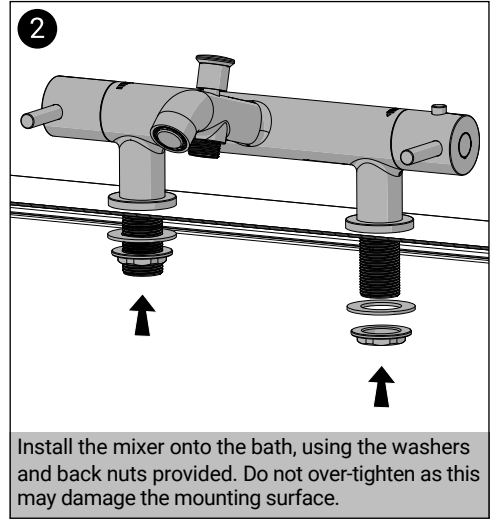
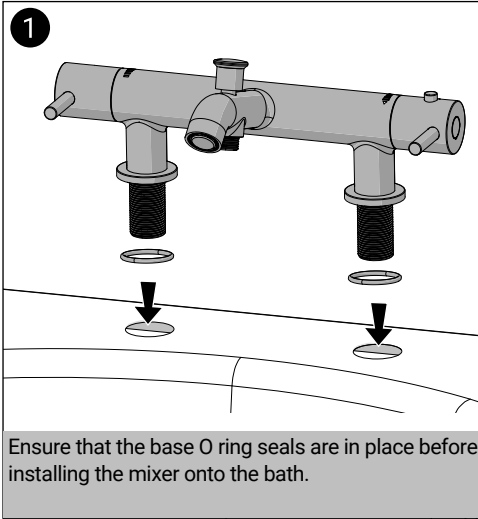

To change from bath to shower mode, pull the diverter lever up. To revert back to bath fill mode, push the diverter lever back down. The maximum temperature is factory set at 38 °C. Hotter temperatures can be obtained by turning the handle past the stop while pressing the temperature override button in. The shower mixer should be cleaned as part of a planned maintenance programme. Do not use abrasive cleaning chemicals or scouring cloths as this will effect the surface finish.

Contact

AKW[®]
Life Made Better

Orders & Quotes

01905 823 299
orders@akw-ltd.co.uk

General Enquiries

01905 823 298
sales@akw-ltd.co.uk

Technical Enquiries

01905 560 219
technicalenquiries@akw-ltd.co.uk

Kitchen Enquiries

01905 823 262
kitchens@akw-ltd.co.uk

Fax

01905 823 297

AKW

Pointon Way, Hampton Lovett
Droitwich Spa, WR9 0LR

www.akw-ltd.co.uk
orders.akw-ltd.co.uk

Follow us on Social:



Guarantee

The life time guarantee only applies to manufacturing or material defects, conditional on the one-time correct installation of the product and does not apply to blockages, inappropriate use or accidental damage. This does not cover damage or defects that result from incorrect installation, lack of maintenance including the build up of grime, dirt or lime-scale and waterborne debris, damage resulting from inappropriate cleaning or water ingress, damage from water freezing or extreme temperature changes. Damage or defects that result from repairs or modifications undertaken by unauthorised persons who are not maintenance engineers. This guarantee excludes general wear and tear through usage and does not apply to surface finishes.

What to do if something goes wrong?

In the event that you should encounter a problem with this product, please contact your local installer and if this does not resolve the issue, then contact AKW technical team who will provide further advice and, if necessary, arrange for a maintenance engineer to visit and report any issues. See the T&Cs on our website or in our catalogue for further information. None of the foregoing affects your statutory rights.